

SOPPORTI MONOBLOCCO DOPPI A GRASSO

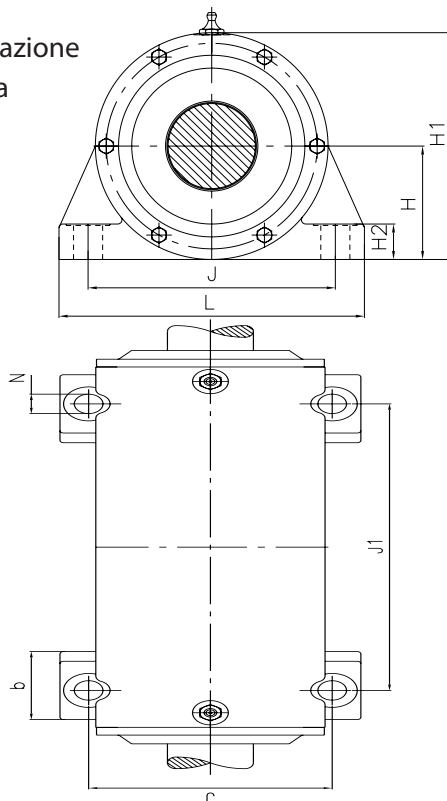

Serie BL
con dischi centrifugatori per la regolazione
del grasso per cuscinetti a sfera
(senza albero e cuscinetti)



Sigla sopporto	d	D	H	H ₁	H ₂	L	J	N	A	L ₂	J ₁	b
[mm]												
BL 25	25	62	50	95	16	155	120	11,5	218	184	135	41
BL 30	30	72	50	100	18	170	130	15	300	266	210	50
BL 35	35	80	60	120	20	190	150	15	330	296	240	50
BL 40	40	90	60	120	20	190	150	15	330	296	240	50
BL 40 S	40	90	60	120	20	190	150	15	450	416	360	50
BL 45	45	100	70	140	23	190	150	15	365	331	263	60
BL 45/K	45	100	70	140	28	200	160	16	260	226	165	64
BL 45/H	45	85	60	118	20	190	150	15	305	282	200	42
BL 50	50	110	70	140	23	190	150	15	365	331	263	60
BL 50 S	50	110	70	140	23	190	150	15	550	516	448	60
BLC 50	50	110	80	150	22	230	175	18	455	421	375	75
BL 55	55	120	80	160	25	210	170	20	405	371	295	70
BL 60	60	130	80	160	25	210	170	20	405	371	295	70
BL 60 SS	60	130	80	160	25	210	170	20	740	706	595	65
BLC 60	60	130	95	175	25	260	200	20	515	481	420	75
BLK 60	60	130	80	160	22	224	190	15	365	349	263	62
BL 70	70	150	95	190	28	270	210	24	450	416	330	80
BL 75	75	160	95	190	28	270	210	24	450	416	330	80
BL 80	80	170	112	217	30	290	230	24	490	450	350	75
BLK 80	80	170	105	210	30	300	250	20	395	375	295	70
BLL 80	80	170	120	240	35	335	280	24	590	566	450	88
BLK 90	90	190	120	240	35	355	280	24	440	416	330	78
BLL 90	90	190	120	240	35	335	280	24	590	566	450	88
BL 95	95	200	125	245	35	340	280	24	540	500	400	80
BL 100	100	215	145	290	40	400	335	24	590	562	450	104
BL 110	110	240	145	290	40	400	335	24	590	562	450	104

Serie BL
con dischi centrifugatori per la regolazione
del grasso per cuscinetti a sfera
(senza albero e cuscinetti)

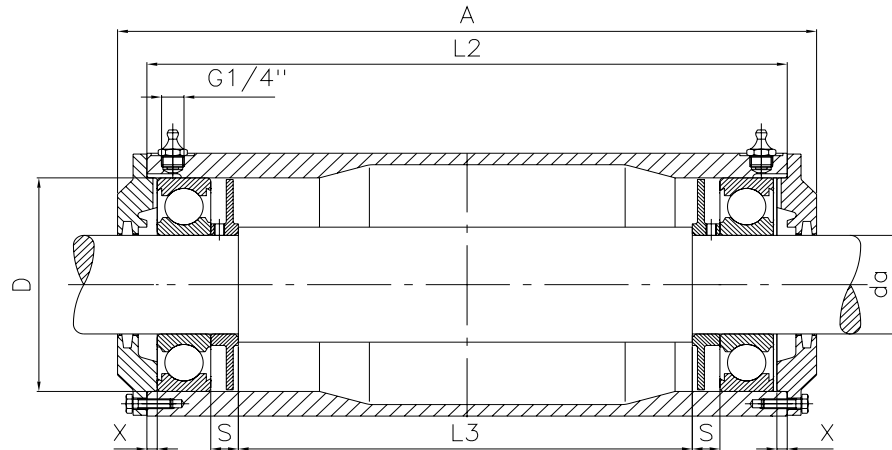

s	x [mm]	L ₃	Sigla corpo	Cuscinetti adatti	Viti di fissaggio del coperchio	Rondella elastica	Numero di giri massimo [min ⁻¹]	Massa [kg]	Grasso [kg] 1°riempimento	rilubrificazione
14	7	108	BL 25	6305 C3	4 x M 6	AS 62	11000	6,5	50	-
14	7	186	BL 30	6306 C3	4 x M 6	AS 72	9000	8	60	5
16	7	208	BL 35	6307 C3	4 x M 6	AS 80	8500	9	80	5
16	7	204	BL 40	6308 C3	4 x M 6	AS 90	7500	10	110	10
16	7	324	BL 40 S	6308 C3	4 x M 6	AS 90	7500	16	110	10
16	7	235	BL 45	6309 C3	4 x M 6	AS 100	6700	14	140	10
16	7	130	BL 45/K	6309 C3	4 x M 6	AS 100	6700	12	140	10
8	15	198	BL 45/H	6209 C3	4 x M 6	AS 85	7500	14	120	10
16	7	231	BL 50	6310 C3	6 x M 6	AS 110	6300	13	190	10
16	7	416	BL 50 S	6310 C3	6 x M 6	AS 110	6300	21	190	10
16	7	321	BLC 50	6310 C3	6 x M 6	AS 110	6300	15	190	10
16	6	269	BL 55	6311 C3	4 x M 8	AS 120	5600	22	240	15
16	6	265	BL 60	6312 C3	6 x M 8	AS 130	5000	21	300	15
16	6	600	BL 60 SS	6312 C3	6 x M 8	AS 130	5000	35	300	15
16	6	375	BLC 60	6312 C3	6 x M 8	AS 130	5000	25	300	15
16	12	231	BLK 60	6312 C3	6 x M 8	AS 130	5000	21	300	15
20	6	294	BL 70	6314 C3	6 x M 8	AS 150	4500	31	480	20
20	6	290	BL 75	6315 C3	6 x M 8	AS 160	4300	32	590	20
20	6	320	BL 80	6316 C3	6 x M 10	AS 170	3800	50	700	20
20	15	227	BLK 80	6316 C3	6 x M 10	AS 170	3800	44	700	20
20	16	416	BLL 80	6316 C3	6 x M 10	AS 170	3800	75	700	20
20	16	258	BLK 90	6318 C3	6 x M 10	AS 190	3400	64	1000	25
20	16	408	BLL 90	6318 C3	6 x M 10	AS 190	3400	85	1000	25
25	6	348	BL 95	6319 C3	6 x M 10	AS 200	3200	60	1150	30
25	16	386	BL 100	6320 C3	6 x M 10	AS 215	3000	95	1450	35
25	16	380	BL 110	6322 C3	6 x M 10	AS 240	2600	86	1900	40

SOPPORTI MONOBLOCCO DOPPI A GRASSO



Serie BL
con dischi centrifugatori per la regolazione
del grasso con cuscinetti a sfera
(completi di albero e cuscinetti)

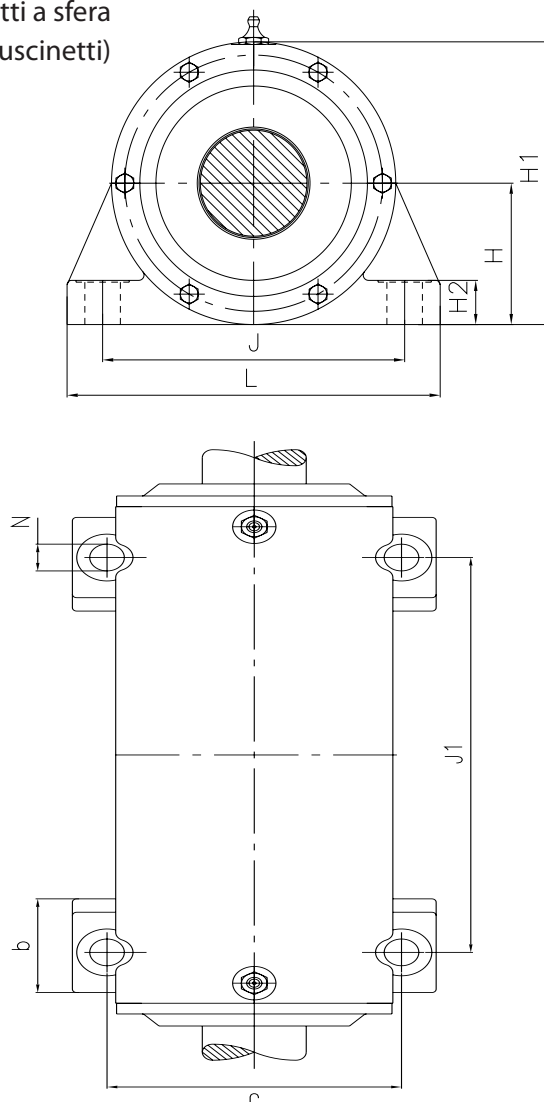

Sigla soffitto	d_1	d	L_1	V	W	X	A	A_1	L_2	J_1	J	L	H	H_1	H_2	N
[mm]																
BL 25 KPL	25	24	358	50	21	19	218	151	184	135	120	155	50	195	16	11,5
BL 30 KPL	30	28	470	50	50	20	300	231	266	210	130	170	50	100	18	15
BL 35 KPL	35	32	530	60	55	25	330	259	296	240	150	190	60	120	20	15
BL 40 KPL	40	38	530	60	55	25	330	257	296	240	150	190	60	120	20	15
BL 45 KPL	45	42	575	65	55	25	365	290	331	263	150	190	70	140	23	15
BL 50 KPL	50	48	585	70	55	25	365	288	331	263	150	190	70	140	23	15
BL 55 KPL	55	50	645	80	55	25	405	328	371	295	170	210	80	160	25	20
BL 60 KPL	60	55	645	80	55	25	405	326	371	295	170	210	80	160	25	20
BL 70 KPL	70	65	755	110	60	25	450	367	416	330	210	270	95	190	28	24
BL 75 KPL	75	70	755	110	60	25	450	365	416	330	210	270	95	190	28	24
BL 80 KPL	80	75	805	110	70	25	490	396	450	350	230	290	112	217	30	24
BLL 80 KPL	80	75	935	120	80	25	590	492	566	450	280	335	120	240	35	24
BLL 90 KPL	90	85	935	120	80	25	590	488	566	450	280	335	120	240	35	24
BLK 100 KPL	100	90	985	120/170	80	25	590	480	562	450	335	400	145	290	40	24
BLK 110 KPL	110	100	985	120/170	80	25	590	480	562	450	335	400	145	290	40	24

Serie BL
con dischi centrifugatori per la regolazione
del grasso con cuscinetti a sfera
(completi di albero e cuscinetti)

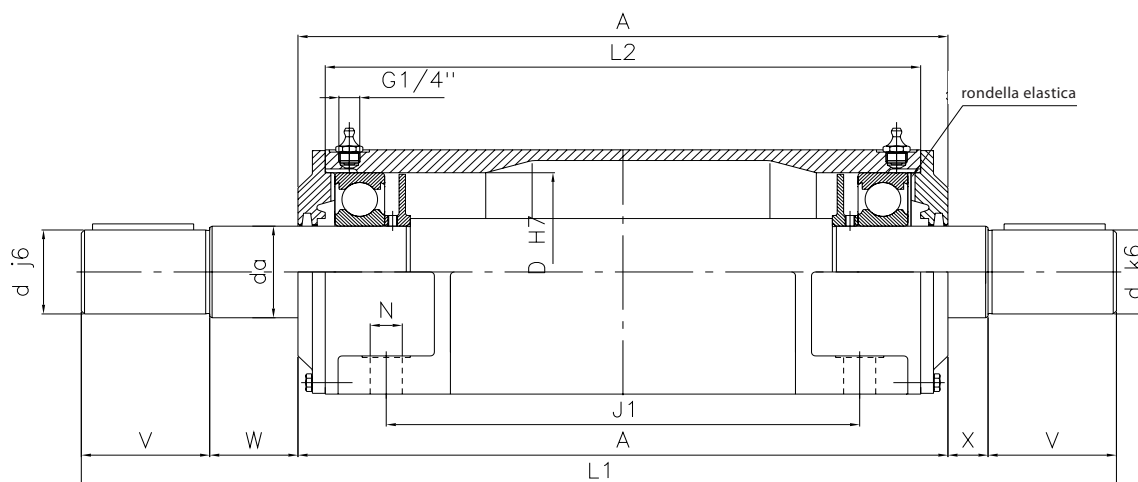

Albero con chiavetta secondo norme DIN 6885. Terminale albero con foro forma D secondo norma DIN 332.

D [mm]	Sigla corpo	Cuscinetti adatti	Viti di fissaggio del coperchio	Rondella elastica	Numero di giri massimo [min ⁻¹]	Massa [kg]	Grasso [kg]	
							1°riempimento	ri lubrificazione
62	BL 25	6305 C3	4 x M 6	AS 62	11000	9	50	5
72	BL 30	6306 C3	4 x M 6	AS 72	9500	12	60	5
80	BL 35	6307 C3	4 x M 6	AS 80	8500	17	80	5
90	BL 40	6308 C3	4 x M 6	AS 90	7500	18	110	10
100	BL 45	6309 C3	4 x M 6	AS 100	6700	28	140	10
110	BL 50	6310 C3	6 x M 6	AS 110	5300	37	190	15
120	BL 55	6311 C3	4 x M 8	AS 120	5300	37	240	15
130	BL 60	6312 C3	6 x M 8	AS 130	5000	39	300	15
150	BL 70	6314 C3	6 x M 8	AS 150	4300	63	480	20
160	BL 75	6315 C3	6 x M 8	AS 160	4000	64	590	20
170	BL 80	6316 C3	6 x M 10	AS 170	3800	84	700	20
170	BLL 80	6316 C3	6 x M 10	AS 170	3400	132	700	20
190	BLL 90	6318 C3	6 x M 10	AS 190	3400	134	1000	25
215	BLK 100	6320 C3	6 x M 10	AS 215	3000	198	1450	35
240	BLK 110	6322 C3	6 x M 10	AS 240	2600	196	1900	40